

AW = drain water	KW = cold water	AFFL = above finished floor level
Dat = dataline	KWw = cold water soft	SFB = separate filling-boiler
EZ = power line (supply)	LR = conduit Ø	VEW = demineralized water
FD = floor opening	CNS = stainless steel (inox)	WD = wall opening
HW-VL = hot water flow	MK = supply channell	WS = wall slot
HW-RL = hot water return	PA = equipotential conductor	WW = warm water
KB = cored hole Ø	STL = control line	WWw = warm water soft

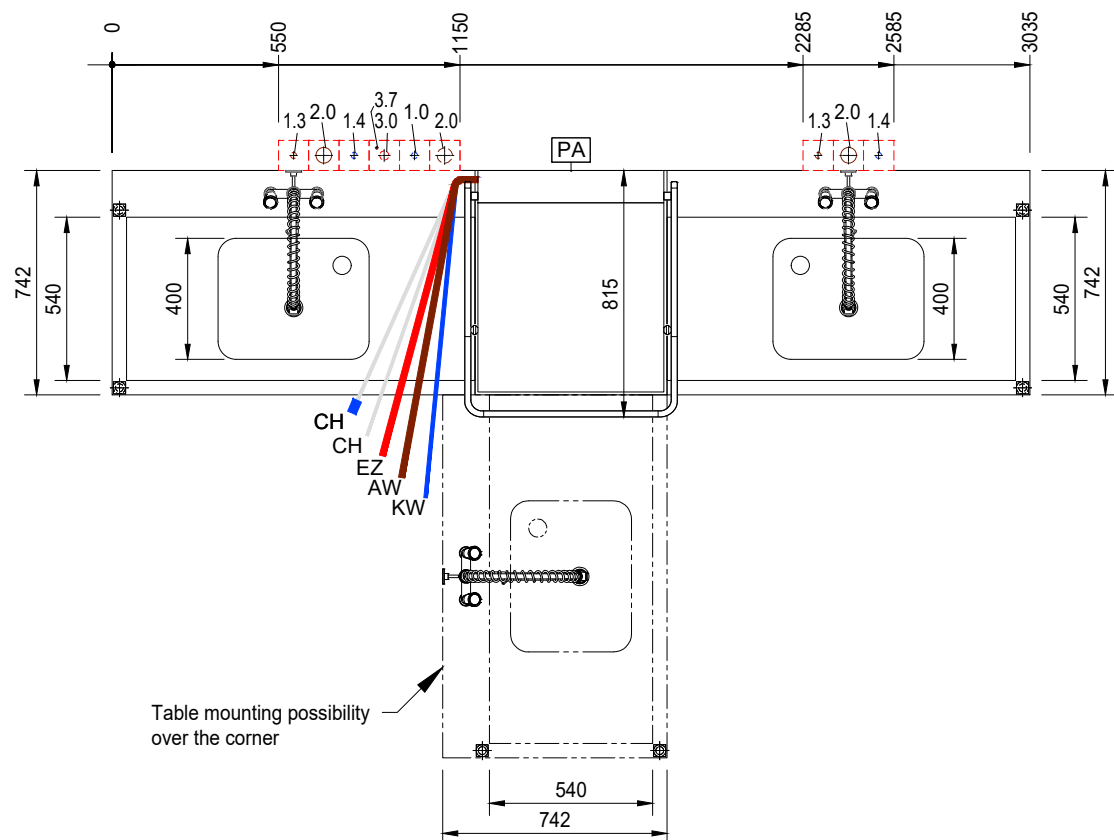
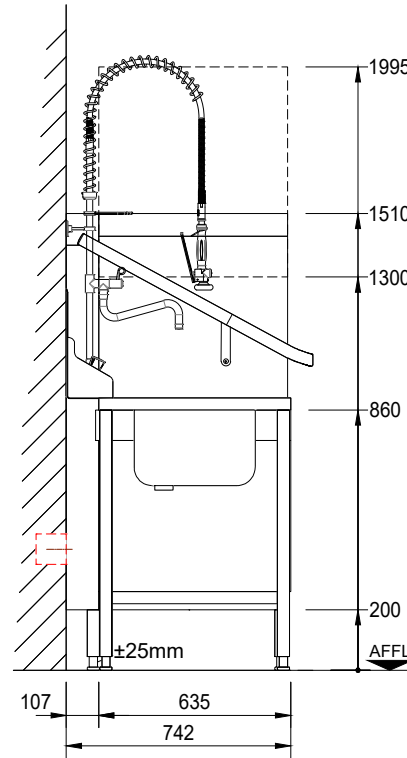
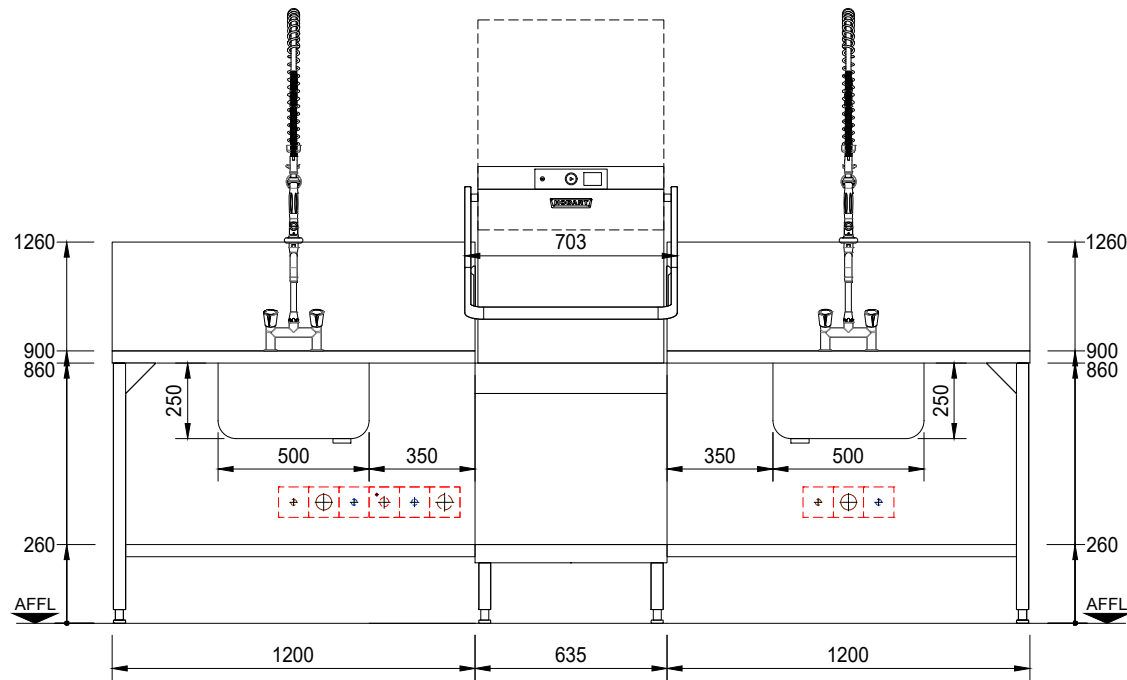

Table connection without Splash panel

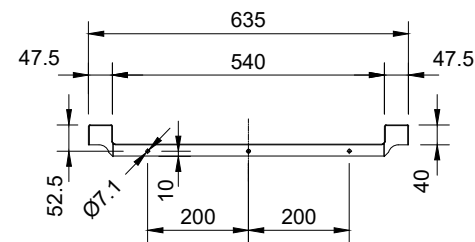
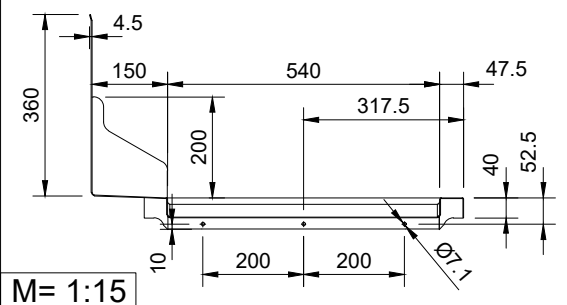

Table connection with Splash panel



Connections: The connection of the dishwasher to all services (e.g. electrical, water, drain, exhaust) must comply with all national and local codes of practice and must be carried out by qualified people.

Attention: If the dishwasher has a frequency inverter included and is connected after a RCD (FI PROTECTIVE SWITCH), this must be AC/DC sensitive type B.

Exhaust: A frost-protection flap is recommended if the exhaust air from the machine is ducted directly outside. If an exhaust hood is installed on top of the dishwasher, an airgap of min. 150mm needs to be maintained. Operational fluctuations can lead to a temporary higher exhaust temperature and humidity (DIN EN 16282-1).

Wash result: A streak free result is achievable with low mineral concentration of the rinse water only (see caption water/conductivity). If necessary a de-mineralization system should be installed.

Dimensions: Dimensions in the drawing are finished dimensions in millimeters.
Transport: Minimum measurements of entry doors = outer largest dimension of machine height + 300mm; machine width + 400mm!

Shut-off valves: The isolating valves for rinse water, tank filling or demi-rinse are to be supplied by others.

Floor drain: Splash floor drains should be installed for machine cleaning and for general cleaning purpose.

Ventilation: The ventilation and exhaust for the room must be according to DIN EN 16282-1. Radiated heat emissions must be considered.

Machine-Type:		Dishwasher				Heating:	Electrical
Model:		PROFI AMXHL-10C				Operation:	L/R/L
Rack size:		500 x 500		Loading height: 440		Main-Switch: by others	
required supply (by others) (all installations according to local regulations) (technical feasibility must be checked on site)							
Electrical	Voltage	Frequency	Structure	Fuse	Total Load	Location	
3.7	PA	Equipotential				400mm AFFL	
3.0	EZ	400 V	50 Hz	3-N-PE	3 x 16 A	6.9 kW	400mm AFFL
Water	Consumption	Temp.	Hardness	Conductance	Dimension	Connection	Location
2.0	AW	Drain (Siphon provided by customer) / (max. drain height 750mm)			DN50	Drain pipe	400mm AFFL
1.4	KW				DN20	G¾ male	400mm AFFL
1.3	WW				DN20	G¾ male	400mm AFFL
1.0	KWw	1.8 l / Rack 23.0 l (Filling)	min. 10 °C max. 60 °C	max. 3.75°e (0,5mmol/l) / 80µS/cm required water flow min. 5l/min	DN20	G¾ male	400mm AFFL
Water-Flow-Pressure provided by customer min. 0,5 bar / 7,3 psi - max. 10 bar / 145 psi (Installation in accordance to DIN 19881)							
machine-side connentions and data							
CH Supply hose for detergent			2000 mm		CH Supply hose for rinse aid (blue marking)		
EZ Power cord			2500 mm		AW Drain hose ID20 / OD25		2000 mm
					KWw Supply hose R¾		2000 mm
Heat-Radiation of the machine (thermal output to the room)							
washware:			2,1 kW		latent:		0,2 kW
					sensible:		0,9 kW

Index Änderungen / Changes Datum / Date Name

Das Urheberrecht an dieser Zeichnung verbleibt bei der HOBART GmbH. Jede nicht von uns schriftlich genehmigte Benutzung, Vervielfältigung, Überlassung an Dritte ist strafbar und macht schadensersatzpflichtig.

This document contains proprietary and confidential data of HOBART GmbH. No disclosure, reproduction or use of any part there of may be made without written permission of HOBART GmbH.

HOBART HOBART GmbH Robert-Bosch-Straße 17 77656 Offenburg, Germany

Tel.: +49(0)781.600-0 Fax.: +49(0)781.600-2319 www.hobart.de

Datum / Date: 30.12.2025	Project:		
Gezeichnet / Drawn by: S.Doll			
Geprüft / Checked by:			
Projectmanager:	Maßstab / Scale: 1:25 @ A3	Order-No.:	Zeichnungsnummer / Drawing-No.: