

AW = drain water	KW = cold water	AFFL = above finished floor level
Dat = dataline	KWw = cold water soft	SFB = separate filling-boiler
EZ = power line (supply)	LR = conduit Ø	VEW = demineralized water
FD = floor opening	CNS = stainless steel (inox)	WD = wall opening
HW-VL = hot water flow	MK = supply chanell	WS = wall slot
HW-RL = hot water return	PA = equipotential conductor	WW = warm water
KB = cored hole Ø	STL = control line	WWW = warm water soft

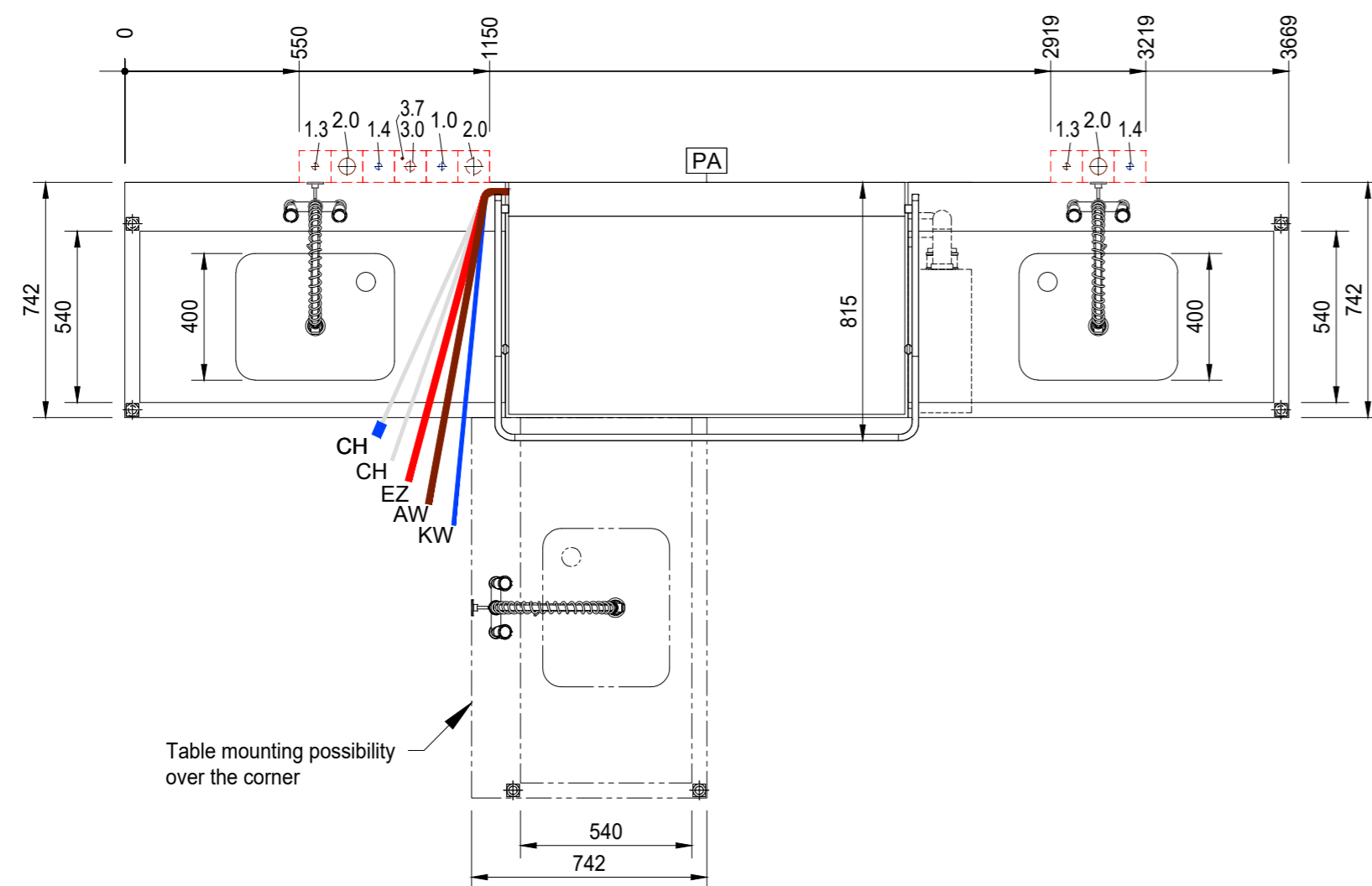
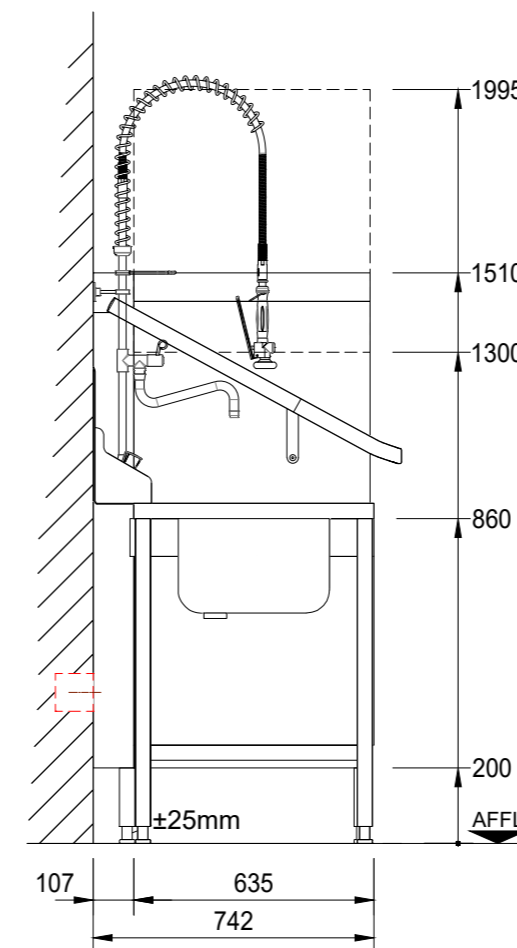
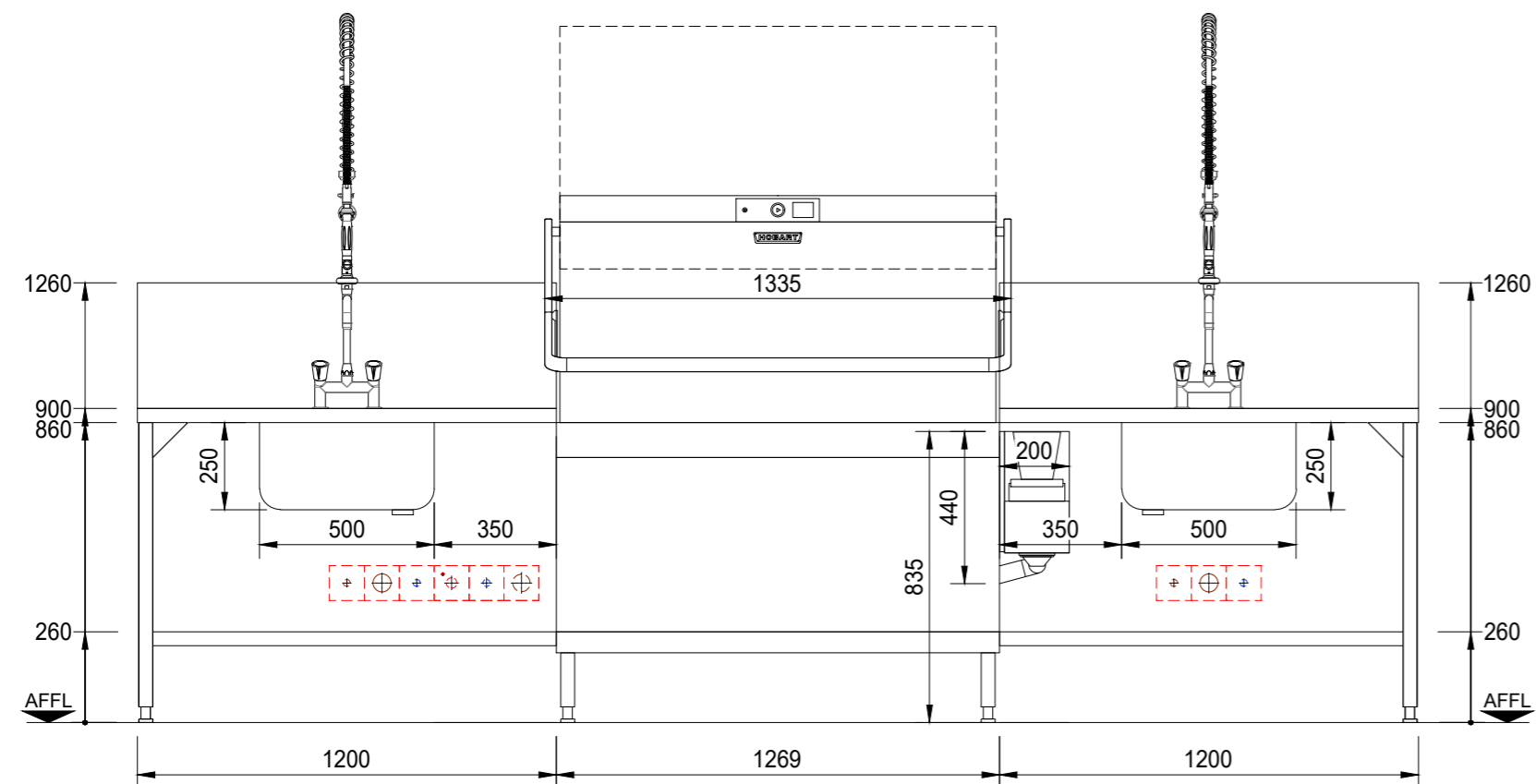

Table connection without Splash panel

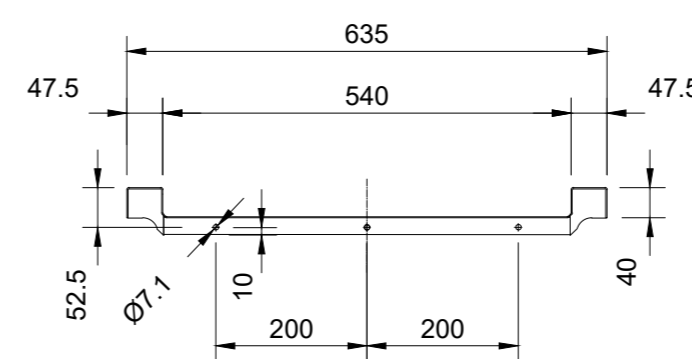
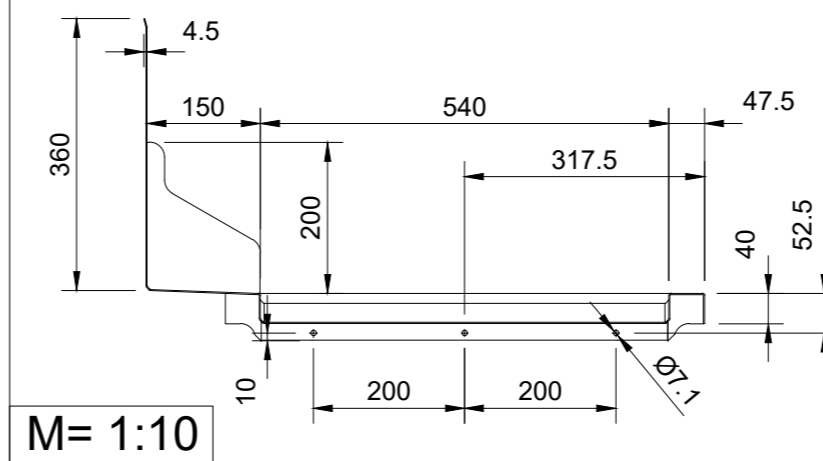

Table connection with Splash panel



M= 1:10

Connections: The connection of the dishwasher to all services (e.g. electrical, water, drain, exhaust) must comply with all national and local codes of practice and must be carried out by qualified people.
Attention: If the dishwasher has a frequency inverter included and is connected after a RCD (FI PROTECTIVE SWITCH), this must be AC/DC sensitive type B.
Exhaust: A frost-protection flap is recommended if the exhaust air from the machine is ducted directly outside. If an exhaust hood is installed on top of the dishwasher, an airgap of min. 150mm needs to be maintained. Operational fluctuations can lead to a temporary higher exhaust temperature and humidity (DIN EN 16282-1).
Wash result: A streak free result is achievable with low mineral concentration of the rinse water only (see caption water/conductivity). If necessary a de-mineralization system should be installed.
Dimensions: Dimensions in the drawing are finished dimensions in millimeters.
Transport: Minimum measurements of entry doors = outer largest dimension of machine height + 300mm; machine width + 400mm!
Shut-off valves: The isolating valves for rinse water, tank filling or demi-rinse are to be supplied by others.
Floor drain: Splash floor drains should be installed for machine cleaning and for general cleaning purpose.
Ventilation: The ventilation and exhaust for the room must be according to DIN EN 16282-1. Radiated heat emissions must be considered.

Machine-Type:		Dishwasher		Heating:	Electrical
Model:		PREMAX AUPT-10C		Operation:	L/R/L
Rack size:		500 x 500		Loading height:	440
				Main-Switch:	by others
required supply (by others) (all installations according to local regulations) (technical feasibility must be checked on site)					
Electrical	Voltage	Frequency	Structure	Fuse	Total Load
3.7	PA	Equipotential			21.9 kW
3.0	EZ	400 V	50 Hz	3-N-PE	3 x 35 A
Water		Consumption	Temp.	Hardness	Conductance
2.0	AW	Drain	(Siphon provided by customer) / (max. drain height 750mm)		DN50
1.4	KW				DN20
1.3	WW				DN20
1.0	KWw	1.4 l / Rack	min. 10 °C	max. 1.25°e (0.2mmol/l) / 80µS/cm	DN20
		80.0 l (Filling)	max. 60 °C	required water flow min. 5l/min	
Water-Flow-Pressure provided by customer min. 0.6 bar / 8.7 psi - max. 10 bar / 145 psi (Installation in accordance to DIN 1988)					
machine-side connetions and data					
CH Supply hose for detergent		2000 mm		CH Supply hose for rinse aid (blue marking)	
EZ Power cord		2500 mm		AW Drain hose ID20 / OD25	
				2000 mm	
				KWw Supply hose R _n	
				2000 mm	
				Heat-Radiation of the machine (thermal output to the room)	
washware:		4,6 kW		latent: 0,4 kW	
				sensible: 1,8 kW	

Index	Änderungen / Changes	Datum / Date	Name
-------	----------------------	--------------	------

Das Urheberrecht an dieser Zeichnung verbleibt bei der HOBART GmbH.
 Jede nicht von uns schriftlich genehmigte Benutzung, Vervielfältigung, Überlassung an Dritte ist strafbar und macht schadensersatzpflichtig.
 This document contains proprietary and confidential data of HOBART GmbH. No disclosure, reproduction or use of any part there of may be made without written permission of HOBART GmbH.

HOBART HOBART GmbH
 Robert-Bosch-Straße17
 77656 Offenburg, Germany
 Tel.: +49(0)781.600-0
 Fax.: +49(0)781.600-2319
 www.hobart.de

Datum / Date:	30.12.2025	Project:	
Gezeichnet / Drawn by:	S.Doll	Maßstab / Scale:	1:20 @ A2
Geprüft / Checked by:		Order-No.:	
Projectmanager:		Zeichnungsnummer / Drawing-No.:	