

HOBART

WAREWASHING
TWO-LEVEL-WASHER TLW



DOUBLE PERFORMANCE

HOBART

TOTAL PERFORMANCE IN YOUR KITCHEN

At HOBART, we take pride in providing reliable and innovative high quality kitchen equipment that has been engineered to ensure that whatever challenges the day may bring - you can make it happen with HOBART.

Let's make it happen!



**SINGLE
MACHINE**



HOBART

7 MARKETS

Countless challenges

1 SOLUTION

DISH AND UTENSIL WASHER TLW



HOSPITALITY

Bar & Pub / Bistro & Café /
Hotel & Restaurant



FOODSERVICE

Hospital / Nursing home /
Canteen / Education - school & university



BAKERY

Bakery subsidiary / Production / Bakery industry



MEAT PRODUCTION

Butchery / Meat production industry



INDUSTRY



GLOBAL MARINE



AIRLINE CATERING





SOMETIMES DOUBLE DOESN'T MAKE SENSE. SOMETIMES IT DOES.

A knife with two blades doesn't make a lot of sense.
"Sometimes double doesn't make sense."

But a dishwasher with two wash levels does:
"Sometimes it does":

The TWO-LEVEL-WASHER (TLW) is unique in the commercial dishwasher market. It's a genius invention from HOBART and boasts an additional washing compartment. A second wash cycle can take place simultaneously in the lower compartment. This means two levels are available for double the washing volume per cycle. With its

increased capacity, this ingenious washing solution offers great potential to relieve kitchen staff and make clean dishes quickly available for reuse. The **PROFI** TWO-LEVEL-WASHER can offer even more with additional innovative features to fulfill the high customer requirements. At peak times, a great variety of different utensils need to be washed in different ways. By selecting the utensil wash programme, heavily soiled pots, pans and cutlery can be thoroughly washed in the lower compartment, whilst dishes are washed in the upper level.

UNIQUENESS MEETS INNOVATION

THE WORLD'S FIRST TWO-LEVEL-WASHER

PROFI TLW

Efficient, space-saving, flexible:

The TWO-LEVEL-WASHER is a real all-rounder and ideal for smaller kitchens.

Despite the second washing level and thanks to its compact design, the TLW does not require more space than a conventional dishwasher.



HOBART

HOBART

PROFI





CLEANING INTELLIGENCE AND WASHING PERFORMANCE

on 2 levels

DOUBLE CAPACITY

Two levels for two-times
the wash volume

At peak times, the wash up area gets hot as dishes pile up and need to be washed quickly for reuse – posing serious challenges to dishwashing staff. Coming to the rescue is the innovative TWO-LEVEL-WASHER with a second chamber where you can wash at the same time, thus doubling the capacity per cycle.

Your benefit

The best thing about the machine is its compact design. It offers double the capacity, but you don't need any more space in your wash up area than with a conventional dishwasher.

HIGH FLEXIBILITY

Wash different wash ware
at the same time

Plates, coffee cups or gastronorm pans: The TWO-LEVEL-WASHER can easily handle all of it. Wash different wash ware in two separate wash chambers at the same time. For example, while porcelain plates are being washed in the upper level, the bottom compartment of the dishwasher provides space for saucers, pans, cooking pots, cutlery or salad bowls.

Your benefit

You save lots of time and have different wash ware ready for reuse when you need it.



CLEANING INTELLIGENCE AND WASHING PERFORMANCE

on 2 levels

SPACE-SAVING WASH ORGANISATION

Suitable and functional for every scullery

Heavily encrusted food on cutlery and cooking utensils is one of the most challenging tasks. To clean the wash ware, manual pre-treatment in a sizeable sink is usually required. The space for this, however, is often not available in small kitchens.

The TWO-LEVEL-WASHER impresses not only with its compact design, but also because it has several wash programmes.

For you this means

In future, dishes can be washed on the top, while underneath heavily soiled wash ware such as pots, pans or cutlery can be washed with the specially developed utensil wash programme. Thanks to the extended washing duration, the soaking effect is integrated into the washing process. Pre-treatment of the wash ware is therefore no longer necessary. Up to three racks can be washed in the upper wash chamber at the same time.

OPTIMAL WASH RESULT

GENIUS-X² FINE FILTER SYSTEM

Constantly keeps the wash solution clean

The enhanced fine filter system cleans soiled water in just three steps, reducing detergent consumption.

The tank stays clean

Coarse soil and food waste are collected in the strainer basket, preventing them from reaching the tank.

Fine soil is removed

The collected fine soil is discharged from the machine after 10 seconds.

Washing does the rest

The residual fine soil is collected during washing and then pumped out.

Bonus benefit

During draining, the system cleans itself automatically, meaning manual cleaning is greatly reduced.

INTERLOCKED STRAINER

Checks whether tank cover strainer and fine filter are correctly inserted

If the strainer system is not in the proper position, the control signals an alarm. The washing cycle can only be continued if the strainer is correctly positioned again.

For you this means

- The pump is protected against broken fragments and small cutlery.
- You benefit from a reduction in detergent consumption and operating costs.
- Soil is kept at bay.

STARCH-REMOVAL WASH PROGRAMME

Smooth, clean plates

Rice, potatoes and pasta contain starch and tend to leave visible traces on plates and bowls. Over time, the tableware not only feels rough, but also looks matte and unhygienic.

A new shine with HOBART

The special starch-removal wash programme ensures that your plates feel completely smooth and clean again. This provides you with the following benefits:

- Time-consuming manual handling of wash ware with aggressive cleaning solutions is eliminated.
- The starch-removal cleaning programme assists your staff and guarantees shining tableware.

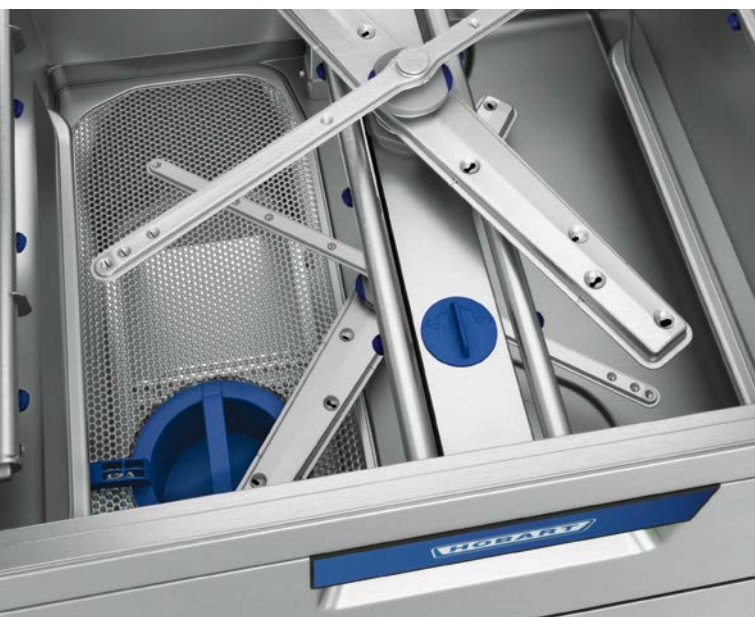



HIGH LEVEL OF ECONOMY

FULLY ENCLOSED HOOD

The clever way of minimising the amount of steam that escapes

Better indoor climate – as standard

Thanks to the fully enclosed hood, the hot waste steam remains in the system and is not released to the room. The indoor climate is thereby less contaminated and energy isn't lost.

Your benefits

- Noticeable improvement of indoor climate in the wash up area.
- Energy loss is reduced significantly.

HEAT AND SOUND INSULATED HOOD

Keep the heat in the machine

Also during operation, the heat is retained in the system. The wash water does not cool off against the 15 mm thick walls of the hood. This increases the heat utilisation and helps to save energy.

SENSO-ACTIVE RESOURCE MANAGEMENT

Responsible water consumption

The quality of the water is monitored constantly and water consumption is adapted accordingly. For low amounts of soil, water consumption remains low; for increased levels of soil, it is increased.

Reduced operating costs

Due to the innovative use of resources alone, operating costs can be significantly reduced.

Your benefits

- Reliable wash results even with high levels of soil.
- TWO-LEVEL-WASHER corrects operating errors.
- Consistent regeneration of the wash solution with sufficient fresh water.
- Complete pump-out and refill is no longer necessary.

EASY HANDLING

VISIOTRONIC-TOUCH CONTROL

Simple operation for everyone

Single-button control in conjunction with a colour touchscreen – it couldn't be easier. The VISIOTRONIC-TOUCH control simplifies use of your machine considerably and shows all the important information in the display using text and symbols.

Your benefits

- Easy selection of programmes.
- Easy settings.
- All important information can be called up at a glance.

REMAINING TIME INDICATOR

A constant overview of the wash cycle

The VISIOTRONIC-TOUCH control clearly displays programme progress

- Blue: Programme just started.
- Partly green: Machine is washing.
- Green: Programme finished / machine ready to start.
- Red: Error or notification.

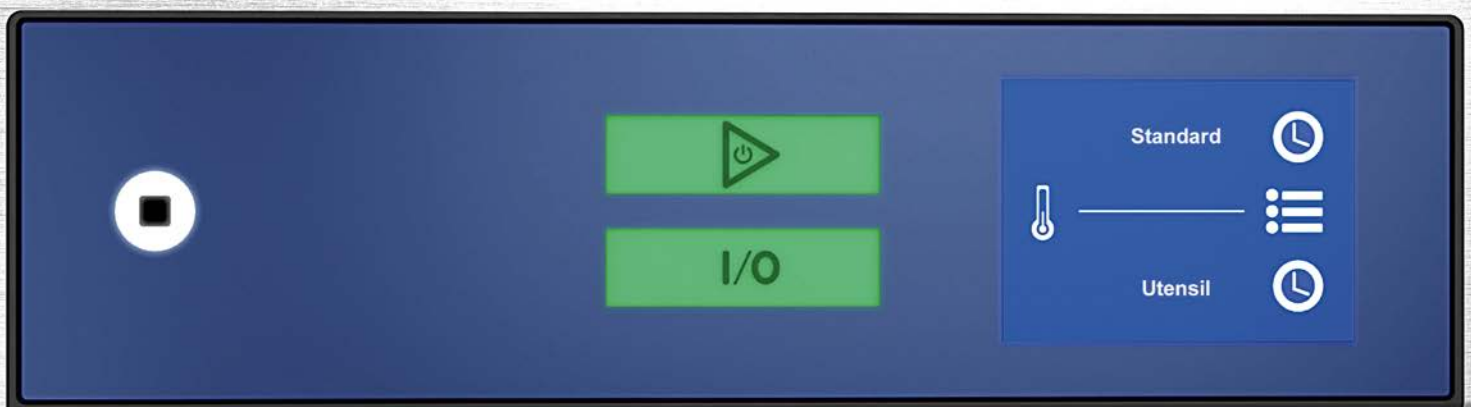
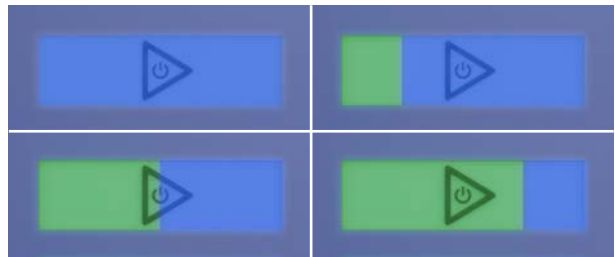

EASY HANDLING

REFILL SIGNAL FOR CHEMICAL CONTAINERS

Level control
efficient and simple

The refill signal system uses optional suction lances to monitor the contents of external chemical containers. This ensures that you are provided with a timely notification of when detergent and rinse aid must be refilled, ensuring problem-free wash results.

INTEGRATED WATER SOFTENER

Protects against calcification
and increases service life

The water softening system, which can optionally be integrated, removes minerals from the water that can cause hardness. This prevents limescale deposits that can cause increased cycle times, burnt-out heating elements and unsatisfactory wash results.

HYGIENE PROGRAMME

Eliminates germs and bacteria

Over time, limescale and soil particles can build up inside your machine. With the hygiene programme, germs and bacteria do not stand a chance.

Alerts on the display tell you when you should next carry out the hygiene programme. After that, it's just a case of putting a hygiene tab into the machine and starting the programme. After just a short time, your TWO-LEVEL-WASHER is hygienically clean again.

An overview of your benefits

- Fast removal of limescale deposits.
- Soil residue is cleaned from the machine.
- Provides a fresh smell.

CLIP-IN WASH AND RINSE SYSTEM

Makes cleaning the machine very simple

To make your work as easy as possible, the wash and rinse system can be removed and reinserted in just one step using the CLIP-IN system.





EASY-CLEAN CONCEPT

Increase the durability of your machine

To maintain the high performance and durability of your dishwasher, you should clean different components daily. The parts are colour-coded to show you clearly which parts need be removed.

USB-INTERFACE

For simple data documentation

Temperature, fault messages and the selected programmes must be permanently documented for monitoring. The VISIOTRONIC-TOUCH control automatically carries out this time-intensive task.

Convenient exporting of operational and consumption data

The TWO-LEVEL-WASHER has a USB-interface for the simple downloading of operational and hygiene parameters. This enables you to save all the relevant data on an external storage device.

ADDITIONAL WASH CHAMBER

More space for increased performance

The second wash chamber of the TWO-LEVEL-WASHER makes it easy to wash GN pans and other cook ware. In addition, up to 320 pieces of cutlery can be washed per cycle in the lower level. There is plenty of space for wash ware such as salad bowls or coffee cups in the lower wash chamber of the machine.

INSTALLATION OPTIONS

For easy integration into the kitchen

The TWO-LEVEL-WASHER can be loaded with racks from both the left and right side, making it easy to integrate the machine into your kitchen processes.

HOBART

HOBART
SMART
CONNECT



SMARTCONNECT



HOBART SMARTCONNECT APP

Key features at a glance

The HOBART SmartConnect app* provides you with a comprehensive overview of the status of your dishwasher.

Connect, learn, benefit

Based on this data, you can avoid downtime and contact HOBART customer service or an approved service partner. SmartConnect also provides illustrated instructions for smaller malfunctions so that you can rectify them yourself.

*Free of charge. Pricing subject to alteration.

You can find more information on the availability of SmartConnect in different countries and languages as well as further information at www.HobartSmartConnect.com.

An overview of all functions

- Machine status (keep up-to-date regarding the statuses of all your machines)
- Machine information (with all important settings and machine information)
- Recording of error messages (in addition, you will be notified by email concerning any system errors)
- Operating costs calculator (overview of the consumption costs)
- Hygiene information (as a log book)
- Operating cycles (information about the efficient use of the machine)



HOBART

HOBART

PROFI



DRAWINGS

TLW

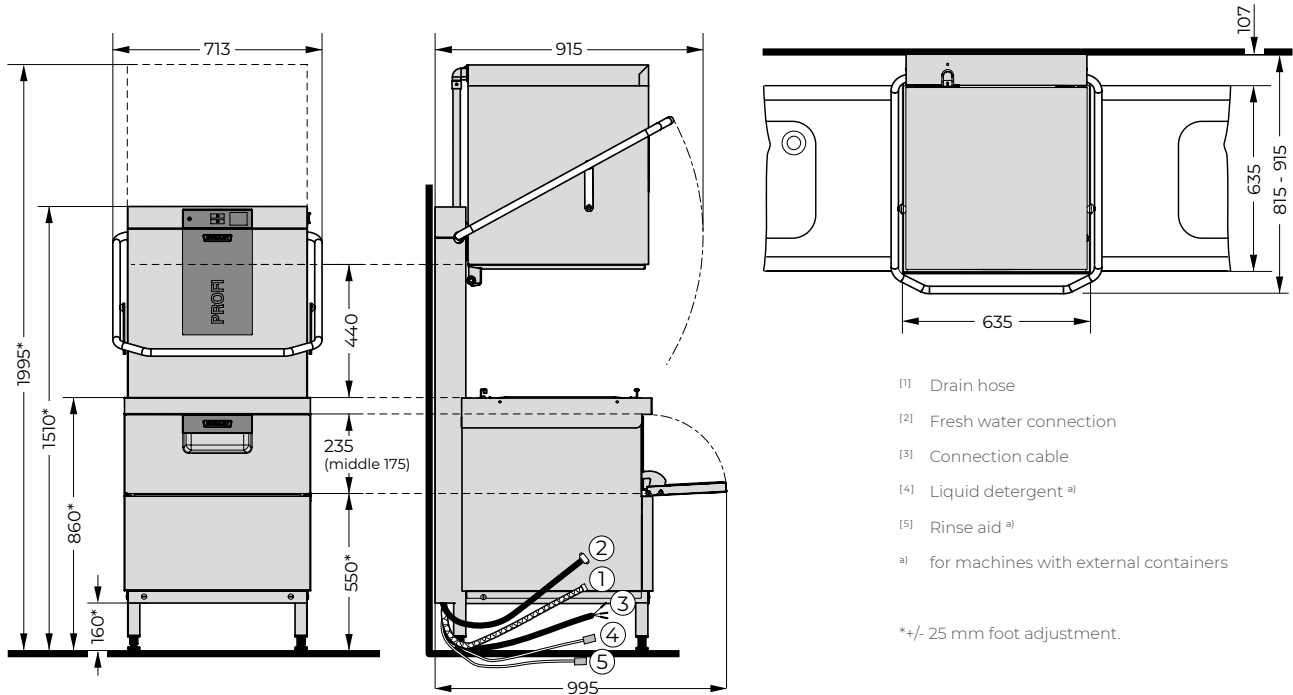

FEATURES

MODELS	PROFI LINE TLW
Double capacity	•
Maximum Flexibility	•
Space-saving wash organisation	•
HIGH LEVEL OF ECONOMY	
Exhaust energy storage	•
Heat and sound insulated hood	•
SENSO-ACTIVE resource management	•
OPTIMAL WASH RESULT	
GENIUS-X ² fine filter system	•
Interlocked strainer	•
Starch-removal cleaning programme	•
EASY HANDLING	
VISIOTRONIC-TOUCH control	•
Remaining time indicator	•
Refill signal	○
Integrated water softener	○
Hygiene programme	•
CLIP-IN wash and rinse system	•
EASY-CLEAN concept	•
USB-interface	•
Integrated WiFi module	•
SmartConnect App*	•
FLEXIBILITY & RELIABILITY	
Additional wash chamber	•
Installation options	•

● Inclusive ○ Optional – Not available

*You can find more information on the availability of SmartConnect in different countries and languages as well as further information at www.HobartSmartConnect.com. Free of charge. Pricing subject to alteration.

TECHNICAL DATA

MODELS	PROFI LINE TLW
CYCLE TIMES*	60 / 90 / 180 sec. and special programmes
CAPACITY	
Racks	120/h
TANK CAPACITY	30 l
WATER CONSUMPTION	Upper level: 2.0 l/rack Lower level: 2.5 l/rack
WASH PUMP	1.2 kW 490 l/min
Tank heating	3.0 kW
BOOSTER LOADING	
Standard	9.1 kW
TOTAL LOADING	
Standard	13.6 kW 3 x 25 A
Alternative	10.4 kW 3 x 16 A
Power supply	400 / 500 / 3N
DIMENSIONS	
Width	635 mm
Depth	742 mm
Height	1,510 mm
Loading height	Upper level: 440 mm Lower level: 235 mm (175 mm in the centre)
Height with open hood	1,995 mm
Rack size	500 x 500 mm

*The machine is equipped with an automatic cycle-time control which ensures hygienic rinse temperatures, even on a cold-water supply or with reduced heating performance.

CONCEPT SOLUTIONS for optimised washing results

WATER TREATMENT

The right solution for every water quality: Water softening plant to prevent the build-up of limescale and osmosis plant for a stainless wash result.

WASHING CHEMICALS

The right detergent for every application – perfectly suited to the individual machine. The HYLINE hygienic range.





OUR VISION

Wash without water

Intensive market research has shown that our customers expect warewashing technology that combines efficiency with optimal performance. We are focused on meeting these demands and they form the foundation of our vision to "wash without water". This vision is our continuous incentive to break new ground in order to constantly reduce the consumption of water, energy and chemicals. We continue pursuing this goal methodically and with innovative solutions.

THE COMPANY

We are HOBART

HOBART is one of the world's leading manufacturers of commercial warewashing technology and a well known supplier of cooking, food preparation, and environmental technology. Established in 1897 in Troy, Ohio, today HOBART employs more than 6,900 employees around the world. At our manufacturing plant in Offenburg, Germany, HOBART develops, produces, and distributes warewashing technology worldwide. The hotel and catering trade, cafeterias, bakeries and butcher shops, supermarkets, airlines, cruise ships, automotive suppliers, research centres and pharmaceutical companies all over the world swear by our innovative products, which have proven for over 125 years.



MADE IN GERMANY

We provide this promise of quality to our customers, and it represents our personal standard upheld by all our staff at HOBART.



OUR FOCUS

Innovative – economical – sustainable

This is our philosophy. With customer benefits always in focus, we continue to develop our products further. Our group's Technological Centre, and our own Innovation Centre for Warewashing Technology at our headquarters in Germany, make this possible. Here, our innovative powers are combined to create products offering genuine added value for our customers. For us, being economical means delivering low operating costs and consuming few resources. For us, being sustainable means responsible handling of resources and a sustainable energy policy. This applies not only to the product in use, but in general to all areas of the organisation, such as purchasing or manufacturing.

HOBART SERVICE

Competent – fast – reliable

HOBART offers a worldwide service partner network for all products. These technicians always carry out maintenance and repair work competently, quickly and reliably. Thanks to regular trainings and many years of experience, they have detailed product knowledge and will help you so that you can focus on your business.

HOBART

GERMANY/AUSTRIA

HOBART GMBH

Robert-Bosch-Straße 17 | 77656 Offenburg
Phone: +49 781 600-0 | info@hobart.de
www.hobart.de
Central sales: +49 180 300 0068

Service – After-sales Service:

Germany: +49 800 600 1313
Austria: +43 820 240 599

AUSTRALIA

HOBART FOOD EQUIPMENT

Unit 1/2 Picken Street | Silverwater NSW | 2128
Phone: +61 2 9714 0200
www.hobartfood.com.au

BELGIUM

HOBART BELGIUM

Industriestraat 6 | 1910 Kampenhout
Phone: +32 16 60 60 40
sales@hobart.be | www.hobart.be

DENMARK

HOBART SCANDINAVIA APS

Håndværkerbyen 27 | 2670 Greve
Phone: +45 43 90 50 12
salg@hobart.dk | www.hobart.dk

FRANCE

COMPAGNIE HOBART

ZI PARIS EST - Allée du Ter Maï - B.P. 68
77312 MARNE LA VALLEE Cedex 2
Phone: +33 1 64 11 60 00
contact@hobart.fr | www.hobart.fr

ITALY

ITW APPLIANCE COMPONENTS SRL

DIVISIONE HOBART ITALIA

Via Visconti di Modrone, 7 | 20122 Milano
info@hobart.it | www.hobart.it

JAPAN

HOBART (JAPAN) K.K.

Suzunaka Building Omori
6-16-16 Minami-Oi | Shinagawa-ku | Tokyo 140-0013
Phone: +81 3 5767 8670
info@hobart.co.jp | www.hobart.co.jp

KOREA

HOBART KOREA LLC

7th Floor | Woosan Bldg | 108 | Bangi-dong
Songpa-gu | Seoul 138-050
Phone: +82 2 34 43 69 01
contact@hobart.co.kr
www.hobart.co.kr

NETHERLAND

HOBART NEDERLAND B.V.

Pompmolenlaan 12 | 3447GK Woerden
Phone: +31 348 46 26 26
info@hobart.nl | www.hobart.nl

NORWAY

HOBART NORGE

Gamle Drammensvei 120 A | 1363 HØVIK
Phone: +47 67 10 98 00
post@hobart.no | www.hobart.no

SINGAPORE

HOBART INTERNATIONAL (S) PTE LTD

158 | Kallang Way | #06-03/05
Singapore 349245
Phone: +65 6846 7117
enquiry@hobart.com.sg
www.hobart.com.sg

SPAIN

HOBART ESPAÑA

DIVISION DE ITW ESPAÑA, S.L.U.

Ctra de Ribes KM 31,7
08520 Les Franqueses del Vallés, Barcelona
Phone: +34 938 605 020
info@hobart.es | www.hobart.es

SWEDEN

HOBART SCANDINAVIA APS

Varuvägen 9 | 125 30 Älvsjö
Phone: +46 8 584 50 920
info@hobart.se | www.hobart.se

SWITZERLAND

GEHRIG GROUP AG

Bäulerwisenstrasse 1 | 8152 Glattbrugg
Phone: +41 43 211 56-56
info@gehriggroup.ch
www.gehriggroup.ch

THAILAND

HOBART (THAILAND)

43 Thai CC Tower Building | 31st FL
Room No. 310-311 | South Sathorn Rd.
Yannawa | Sathorn | Bangkok | 10120
Phone: +66 2 675 6279 81
enquiry@hobartthailand.com
www.hobartthailand.com

UNITED KINGDOM

HOBART UK

Southgate Way | Orton Southgate
Peterborough | PE2 6GN
Phone: +44 844 888 7777
customer.support@hobartuk.com
www.hobartuk.com

OTHER COUNTRIES

HOBART GMBH

Robert-Bosch-Straße 17 |
77656 Offenburg | Germany
Phone: +49 781 600-2820
info-export@hobart.de
www.hobart-export.com

Die Angaben in diesem Prospekt beruhen auf dem Stand 04/2026. Technische Änderungen oder Änderungen der Ausführung bleiben vorbehalten.

The details given in this brochure are correct as of 04/2026. We reserve the right to technical or design modifications.

Document non contractuel. Les indications de ce prospectus sont conformes à la mise à jour de 04/2026. Nous nous réservons le droit de modifier les données ou les configurations techniques de nos machines.

