

ecomaxTM
by **HOBART**

GLASS, DISH AND UTENSIL WASHER



made in germany

LOW PRICE
HIGH PERFORMANCE



OVERVIEW OF OUR MODELS

ecomax[™]
by **HOBART**

The entry-level models for those who search for a low-cost dishwasher for commercial use. Ideal for start-ups and companies with irregular washing frequency, who invest in a dishwasher for the first time. **ecomax** meets all requirements for hygienic wash results.

Model G404
Compact glasswasher



Model F504
Undercounter dishwasher



ecomax
by **HOBART** **plus**

For budget-oriented operators who seek a plus for comfort and equipment. **ecomax plus** combines all the features of an **ecomax** dishwasher and offers a plus for wash power, energy efficiency, noise reduction and ease of use.

Model G415
Compact glasswasher



Model F515
Undercounter dishwasher



Model F515L
Undercounter dishwasher
with deeper wash chamber



plus

LOW PRICE
HIGH PERFORMANCE



OVERVIEW OF OUR MODELS

made in germany

ecomax[™]
by **HOBART**

Model H604
Hood-type dishwasher



ecomax[™] **plus**
by **HOBART**

Model H615
Hood-type dishwasher



Model U704
Utensil washer



plus

ECOMAX G404 COMPACT GLASSWASHER

The fast and reliable glasswasher in compact design. Perfect for start-ups, small bars or restaurants.



FEATURES

- Single-button control with digital temperature indication, 3 programmes and further special cycles
- Rotating wash and rinse arms for an even water distribution
- Indented nozzles prevent blocking
- Integrated counter for cycles and water consumption, e.g. for control of water treatment system
- Double-walled housing and door
- Deep drawn rack track for easy cleaning
- USB connection for easier service access
- Incl. connection cable, supply and drain hose for immediate operation
- Thermostop function for guaranteed temperatures
- Hygiene programme for hygienic cleanliness
- Refill signal monitors fill level of external chemical containers with optional suction lances





ECOMAX PLUS G415 COMPACT GLASSWASHER

The compact glasswasher for hotels, bars and restaurants, that are washing more than a hundred glasses a day.

plusFEATURES

+++ additional to ecomax +++

- + Optimal wash results thanks to additional cutlery cycle
- + Deep-drawn wash tank for easy cleaning
- + Double-walled, insulated housing and thermally insulated front door for reduction of noise and energy losses
- + Better energy efficiency saves operating costs
- + Tank strainer, coarse filter and pump suction casing secure safe operation
- + Door damping control for long life operation
- + Fully equipped with rinse pressure pump, detergent and rinse aid dispenser and drain pump





ECOMAX F504 DISHWASHER

With a high capacity of up to 60 racks per hour, this dishwasher is a reliable partner for club houses, bistros, and fast-food restaurants. The practical floor unit fits under every work counter.

FEATURES

- Single-button control with digital temperature indication, 3 programmes and further special cycles
- Rotating wash and rinse arms for an even water distribution
- Indented nozzles prevent blocking
- Integrated counter for cycles and water consumption, e.g. for control of water treatment system
- Deep drawn rack track for easy cleaning
- Double-walled housing and door
- Refill signal monitors fill level of external chemical containers with optional suction lances
- USB connection for easier service access
- Incl. connection cable, supply and drain hose for immediate operation
- Thermostop function for guaranteed temperatures
- Hygiene programme for hygienic cleanliness
- Tank strainer reduces soiling of the tank water
- Rinse pressure pump for optimum flow pressure
- Optional cabinet base for ergonomic operation



ECOMAX PLUS F515 / F515L DISHWASHER

Due to the high wash power and the robust filter systems, it is the quiet and resource-saving solution for your busy workday life.

plusFEATURES

+++ additional to ecomax +++

- + Optimal wash results thanks to additional cutlery and glasswashing cycle
- + Deep-drawn wash tank for easy cleaning
- + Double-walled, insulated housing and thermally insulated front door for reduction of noise and energy losses
- + Better energy efficiency saves operating costs
- + Coarse filter secures safe operation
- + Door damping control for long life operation
- + Fully equipped with rinse pressure pump, detergent and rinse aid dispenser and drain pump



F515L FEATURE

- + Extra deep wash chamber suitable to wash trays of 600 x 400 mm or EN containers

F515 FEATURE

- + Bottle washing programme for the hygienic cleaning of bottles with optional bottle washing system, consisting of spray attachment, wire attachment and bottle rack



ECOMAX H604 HOOD-TYPE DISHWASHER

The ecomax hood-type dishwasher is, combined with tables, a powerful partner for the catering and hotel sector.

FEATURES

- The 4-sided closed hood keeps energy and humidity in the system
- Electronic control with digital temperature indication and 3 programmes for easy operation
- Deep-drawn wash tank for easy cleaning
- Rotating wash and rinse arms for an even water distribution
- Refill signal monitors fill level of external chemical containers with optional suction lances
- Intended nozzles prevent blocking
- Incl. connection cable, supply and drain hose for immediate operation
- Thermostop function for guaranteed temperatures





ECOMAX H615 HOOD-TYPE DISHWASHER

The hood-type dishwasher for ergonomic and efficient work processes in the kitchen, thanks to the single-button control on top and the all-around handle.

plusFEATURES

+++ additional to ecomax +++

- + Single-button control on top of the hood with digital temperature indication, 3 programmes and further special cycles
- + All-around handle for an ergonomic hood lift
- + Reduced rinse water consumption
- + Hygiene programme for hygienic cleanliness

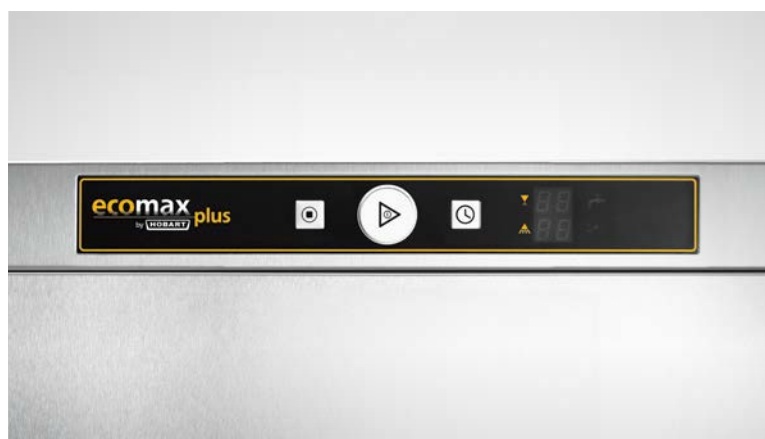

ECOMAX U704 UTENSIL WASHER

The ecomax utensil washer, which perfectly cleans large items and heavily soiled utensils.

FEATURES

- Loading of high trays and pots: up to 630 mm loading height
- Single-button control with digital temperature indication, 3 programmes and further special cycles
- Deep-drawn wash tank for easy cleaning
- Double-walled, insulated housing and thermally insulated front door for reduction of noise and energy losses
- Rotating wash and rinse arms for an even water distribution
- Refill signal monitors fill level of external chemical containers with optional suction lances
- Intended nozzles prevent blocking
- Incl. connection cable, supply and drain hose for immediate operation
- Thermostop function for guaranteed temperatures
- Hygiene programme for hygienic cleanliness



HYDRILINE WATER TREATMENT



The right water quality for your application – whether your focus is on protecting your machine efficiently against limescale, or on ensuring that your wine glasses are free of stains after washing.

External single-chamber softener SE-H

Protects heating rods against limescale and reduces detergent consumption. Quantity-controlled automatic regeneration.

External double-chamber softener SD-H

Protects heating rods against limescale and reduces detergent consumption. Regeneration takes place parallel to the cleaning process.

Partial demineralisation cartridge STAR PD

Removal of hardness components from the water.

Full demineralisation cartridge STAR EXTRA FD

Removes all minerals from the water. For brilliant wash results for glasses and cutlery.

Reverse osmosis RO-S

Removes all minerals and particles from the water. For brilliant wash results for glasses and cutlery.

HYLINE HYGIENE RANGE DETERGENT / RINSE AID



*Highly-concentrated liquid detergents for use in commercial dishwashers. Extremely effective and therefore economic in use. Tailor-made for **ecomax** and **ecomax plus** dishwashers.*

Highly-concentrated rinse aid for use in commercial dishwashers. Makes glasses and cutlery shining and provides a spotlessly clean wash result.



DRAWINGS

UNDERCOUNTER GLASS AND DISHWASHERS

Glasswasher G404

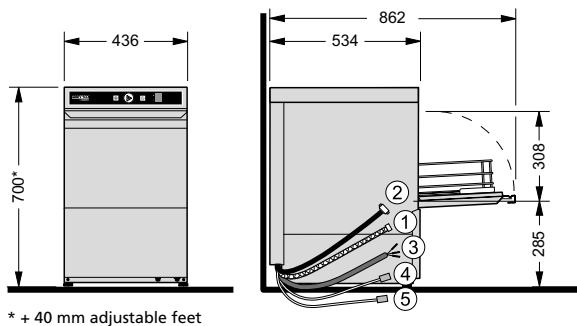

* + 40 mm adjustable feet

Glasswasher G415

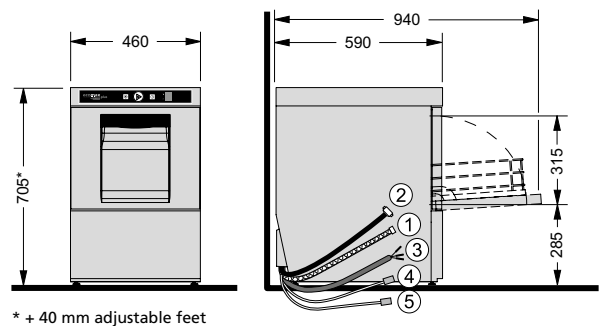

* + 40 mm adjustable feet

Undercounter dishwasher F504

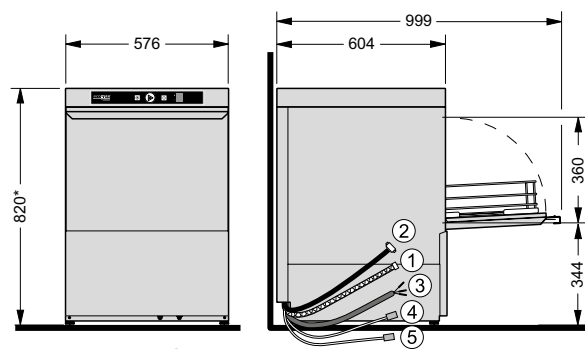

* + 40 mm adjustable feet

Undercounter dishwasher F515

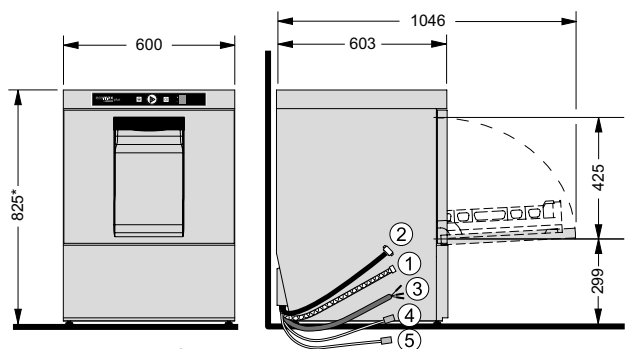

* + 40 mm adjustable feet

Undercounter dishwasher F515L

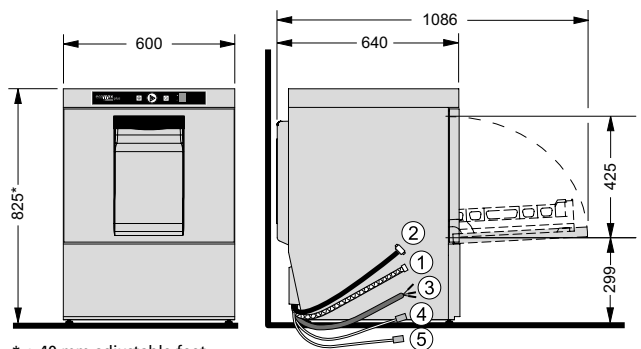

* + 40 mm adjustable feet

- ① Drain hose
- ② Supply hose
- ③ Connection cable
- ④ Liquid detergent ^{a)}
- ⑤ Rinse aid ^{a)}

^{a)} for machines with external containers

plus

DRAWINGS

HOOD-TYPE AND UTENSIL WASHERS

Hood-type dishwasher H604

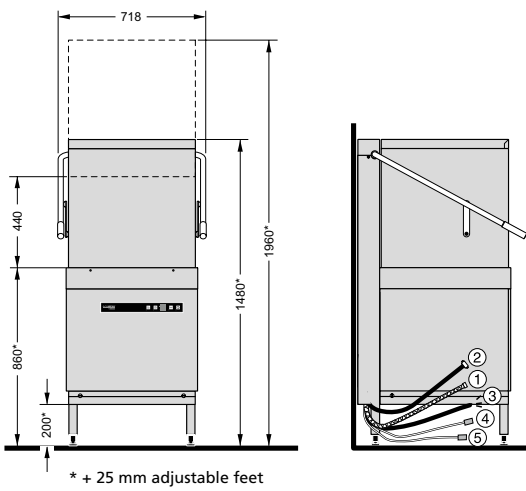

Hood-type dishwasher H615

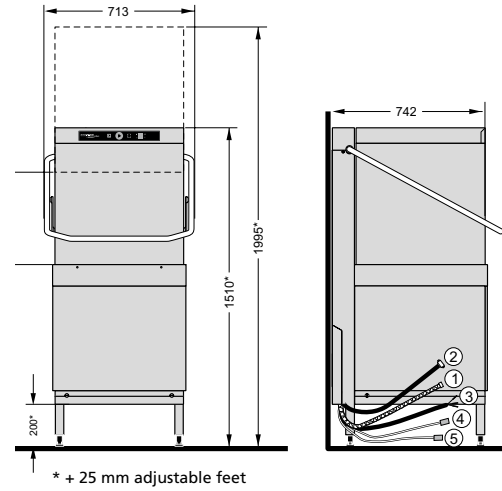

Utensil washer U704

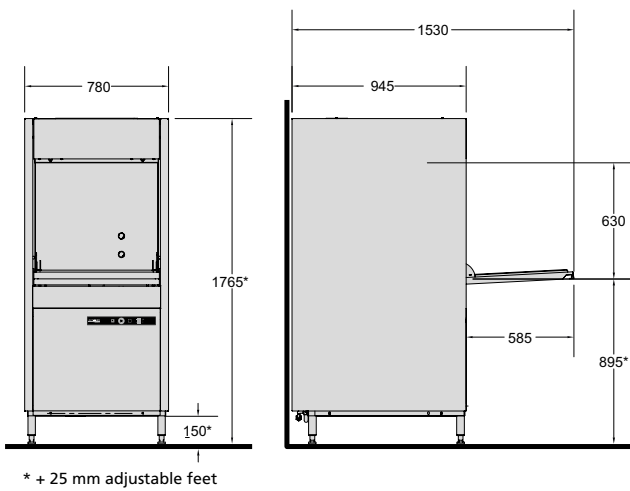

- ① Drain hose
- ② Supply hose
- ③ Connection cable
- ④ Liquid detergent ^{a)}
- ⑤ Rinse aid ^{a)}

^{a)} for machines with external containers

plus

FEATURES

MODELS	GLASSWASHER						UNDERCOUNTER DISHWASHER							
	G404 -10	G404 S-10	G404 -12	G404 S-12	plus		F504 -10	F504 S-10	F504 -12	F504 S-12	plus			
					G415 -11	G415 S-10					F515 -11	F515 S-11	F515L -11	F515L S-11
Integrated water softener*	-	●	-	●	-	●	-	●	-	●	-	●	-	●
Double-walled housing – insulated	-	-	-	-	●	●	-	-	-	-	●	●	●	●
Double-walled housing	●	●	●	●	-	-	●	●	●	●	-	-	-	-
Deep-drawn wash tank	-	-	-	-	●	●	-	-	-	-	●	●	●	●
Door damping control	-	-	-	-	●	●	-	-	-	-	●	●	●	●
Tank strainer	-	-	-	-	●	●	●	●	●	●	●	●	●	●
Drain pump	○	○	●	●	●	●	○	○	●	●	●	●	●	●
Rinse pressure pump**	-	●	-	●	●	●	●	●	●	●	●	●	●	●
Rinse aid dispenser	●	●	●	●	●	●	●	●	●	●	●	●	●	●
Detergent dispenser	○	○	●	●	●	●	○	○	●	●	●	●	●	●
Chemical suction lances	○	○	○	○	○	○	○	○	○	○	○	○	○	○
Bottle washing system	-	-	-	-	-	-	-	-	-	-	○	○	-	-
Deeper wash chamber	-	-	-	-	-	-	-	-	-	-	-	-	●	●
Base cabinet (435 mm high) with removable door	-	-	-	-	-	-	○	○	○	○	○	○	○	○
Glass rack (4 sloped rows) 00-139321-057	●	●	●	●	-	-	-	-	-	-	-	-	-	-
Glass rack (4 sloped rows) 371450-84	-	-	-	-	●	●	-	-	-	-	-	-	-	-
Plate rack P-18-12	-	-	-	-	-	-	●	●	●	●	●	●	●	●
Cutlery box CB1	○	○	○	○	○	○	●	●	●	●	○	○	○	○
Cutlery rack with 4 boxes 01-246175-1	-	-	-	-	-	-	○	○	○	○	●	●	●	●
Universal flat rack B-00-07	-	-	-	-	-	-	○	○	○	○	●	●	●	●

* For machine protection the water hardness should not exceed 3°dH, if higher we recommend using an integrated water softener or an external water treatment system.

** Necessary flow pressure without rinse pressure pump: 2 - 6 bar. Flow pressure with integrated rinse pressure pump: 0.8 - 6 bar.

● Inclusive ○ Optional

FEATURES

made in germany

MODELS	HOOD-TYPE DISHWASHER					UTENSIL WASHER	
	H604 -10	H604 -12	H604 S-12	plus		U704 -10	U704 -11
				H615 -10	H615 S-10		
Integrated water softener*	–	–	●	–	●	–	–
Double-walled housing – insulated	–	–	–	–	–	●	●
Deep-drawn wash tank	●	●	●	●	●	●	●
Door damping control	–	–	–	–	–	●	●
Tank strainer	●	●	●	●	●	●	●
Drain pump	○	●	●	●	●	○	●
Rinse pressure pump**	–	●	●	●	●	●	●
Rinse aid dispenser	●	●	●	●	●	○	●
Detergent dispenser	○	●	●	●	●	○	●
Chemical suction lances	○	○	○	○	○	○	○
HOBART tabling programme	○	○	○	○	○	○	○
Plate rack P-18-12	●	●	●	●	●	–	–
Cutlery box CB1	●	●	●	○	○	–	–
Cutlery rack with 4 boxes 01-246175-1	○	○	○	○	○	–	–
Cutlery rack with 8 boxes CB8	○	○	○	●	●	–	–
Universal flat rack 01-510508-1	–	–	–	–	–	○	○
Universal flat rack B-00-07	○	○	○	●	●	–	–

* For machine protection the water hardness should not exceed 3°dH, if higher we recommend using an integrated water softener or an external water treatment system.

** Necessary flow pressure without rinse pressure pump: 2 - 6 bar. Flow pressure with integrated rinse pressure pump: 0.8 - 6 bar.

● Inclusive ○ Optional

TECHNICAL SPECIFICATIONS



TECHNICAL SPECIFICATIONS

made in germany

MODELS	ecomax [™] by HOBART				ecomax [™] plus by HOBART			
	G404	F504	H604	U704	G415	F515	F515L	H615
Cycle times*	60/120/180 s	60/120/180 s	75/150/180 s	120/240/360 s	60/120/180 s	60/120/180 s	60/120/180 s	60/90/180 s
Rack capacity	60 /h	60 /h	48 /h	30 cycles/h	60 /h	60 /h	60 /h	60 /h
Tank capacity	10 l	25 l	21 l	80 l	8 l	10.6 l	10.6 l	23 l
Water consumption	1.8 l/rack	2.0 l/rack	2.3 l/rack	4.5 l/cycle	1.8 l/rack	2.0 l/rack	2.0 l/rack	2.2 l/rack
Wash pump	0.18 kW	0.34 kW	0.4 kW	2.9 kW	0.4 kW	0.5 kW	0.5 kW	0.7 kW
Tank heating	1.8 kW	1.8 kW	2.5 kW	3.3 kW	0.8 kW	0.8 kW	0.8 kW	2.5 kW
BOOSTER LOADING								
Standard	1.8 kW (230 V)	5.5 kW (400 V)	6.2 kW (400 V)	9.0 kW (400 V)	2.8 kW (230 V)	6.2 kW (400 V)	6.2 kW (400 V)	6.2 kW (400 V)
Alternative	5.5 kW (400 V)	1.8 kW (230 V)	–	–	4.1 kW (400 V)	2.0 kW (230 V)	2.0 kW (230 V)	4.1 kW (230 V)
TOTAL CONNECTED LOAD								
Standard	2.1 kW (230 V)	5.9 kW (400 V)	6.6 kW (400 V)	12 kW (400 V)	3.2 kW (230 V)	6.7 kW (400 V)	6.7 kW (400 V)	6.9 kW (400 V)
Alternative	5.7 kW (400 V)	2.2 kW (230 V)	–	–	5.4 kW (400 V)	2.6 kW (230 V)	2.6 kW (230 V)	4.9 kW (230 V)
Rated voltage	230/50/1 (400/50/3N)	400/50/3N (230/50/1)	400/50/3N –	400/50/3N –	230/50/1 (400/50/3N)	400/50/3N (230/50/1)	400/50/3N (230/50/1)	400/50/3N (230/50/1)
Width	436 mm	576 mm	635 mm	780 mm	460 mm	600 mm	600 mm	635 mm
Depth	534 mm	604 mm	742 mm	945 mm	590 mm	603 mm	640 mm	742 mm
Height	700 mm	820 mm	1,480 (1,960) mm	1,765 mm	705 mm	825 mm	825 mm	1,510 (1,995) mm
Loading height	308 mm	360 mm	440 mm	630 mm	315 mm	425 mm	425 mm	440 mm
Rack size	390x390 mm	500x500 mm	500x500 mm	600x760 mm	400x400 mm	500x500 mm	500x500 mm	500x500 mm

* The machine is equipped with an automatic cycle-time control which ensures hygienic rinse temperatures even on a cold-water supply or with reduced heating performance.



A registered brand of HOBART GmbH
A company of the ITW Group

Robert-Bosch-Straße 17 · 77656 Offenburg
info@ecomaxbyhobart.com · Phone +49 781 600-2820

www.ecomaxbyHOBART.com



The details given in this brochure are correct as of 01/2026.
We reserve the right to technical or design modifications.

